

## Used Oil Evacuation Systems

308719G

ENG

### **Model 224873, Series A**

*Wall-mount 716 diaphragm pump evacuation system, used-oil receiver must be ordered separately*

### **Model 222090, Series A**

*Wall-mount 1040 diaphragm pump evacuation system, used-oil receiver must be ordered separately*

### **Model 24E166, Series A**

*Wall-mount 1050 diaphragm pump evacuation system, used-oil receiver must be ordered separately*

PROVEN QUALITY. LEADING TECHNOLOGY.

# Parts

## Model 224873, Series A

Wall-mount 716 diaphragm pump system without used-oil receiver  
(includes items 1 through 5)

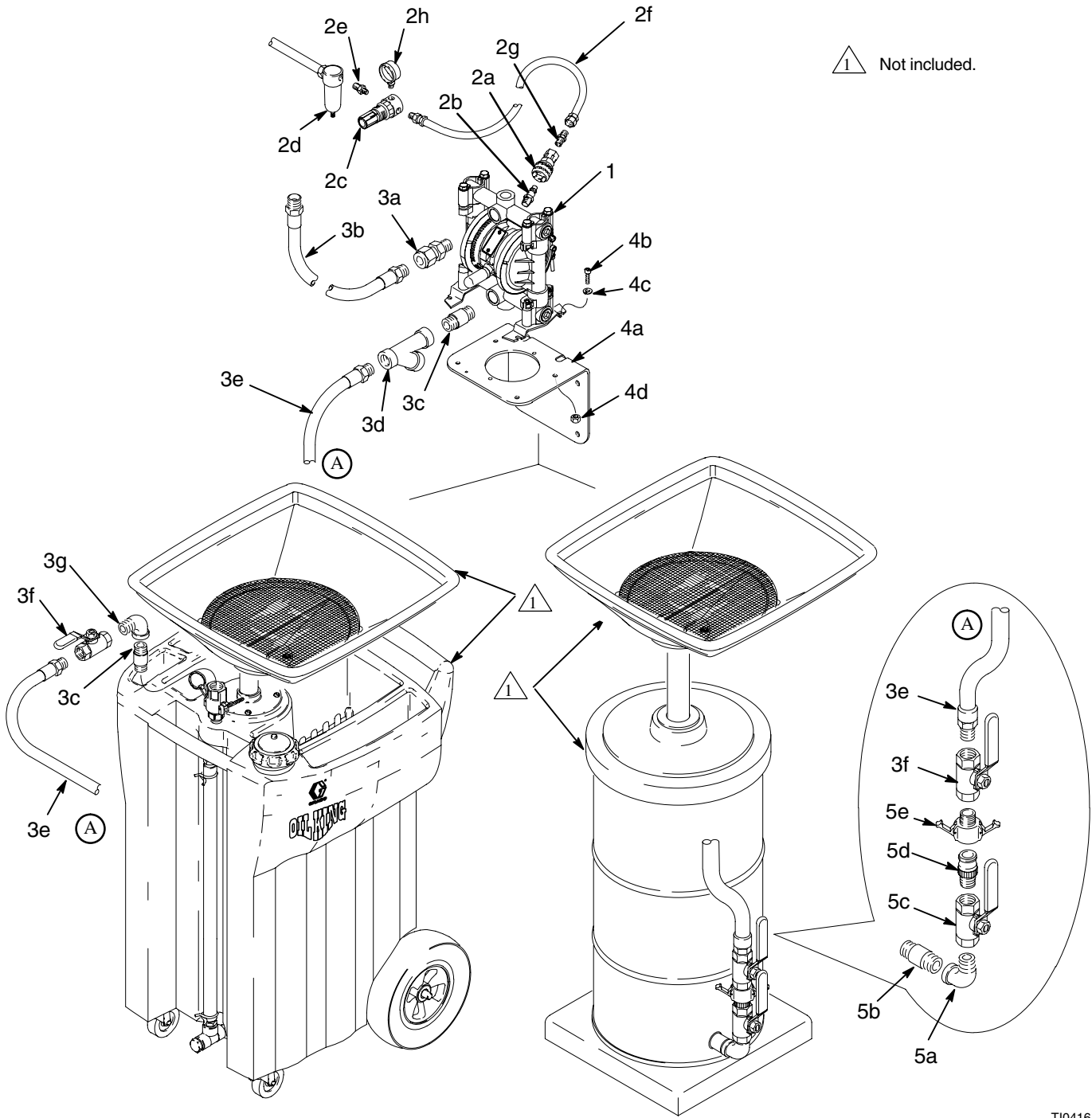

T10416

# Parts

## Model 224873, Series A

Wall-mount 716 diaphragm pump system without used-oil receiver  
(includes items 1 through 5)

Ref No.	Part No.	Description	Qty.	Ref No.	Part No.	Description	Qty.
1	241906	716, 3/4-in (19.1 mm) diaphragm pump (See manual 308573)	1	3d	101078	. Y-STRAINER, female; 3/4 npt	1
2	240684	KIT, installation, air (includes items 2a through 2h)		3e	111010	. HOSE, fluid, coupled; 10 ft (3.1 m)	1
2a	114558	. COUPLER, female, air line; 1/4-in (6.4 mm)	1	3f	109077	. VALVE, ball; 3/4 npt	1
2b	169970	. FITTING, male, air line; 1/4-in (6.4 mm)	1	3g	100549	. ELBOW, street; 3/4 npt(f) x 3/4 npt(m)	1
2c	104815	. REGULATOR, air; 1/8 npt	1	4	224835	KIT, accessory, wall bracket (includes items 4a through 4d)	
2d	110146	. FILTER, air; 1/4 npt	1	4a	*	. BRACKET, wall	1
2e	151519	. NIPPLE; 1/4 npt x 1/8 npt	1	4b	104119	. SCREW, cap	4
2f	183595	. HOSE, air; 30-in (762 mm)	1	4c	104123	. WASHER, lock	4
2g	162453	. NIPPLE; 1/4 npt x 1/4 npsm	1	4d	102025	. NUT, hex	4
2h	104655	. GAUGE, air pressure; 1/8 npt	1	5	240832	KIT, adapter, drum-style; (includes items 5a through 5e)	1
3	240685	KIT, installation, fluid (includes items 3a through 3g)		5a	100549	. ELBOW, street; 3/4 npt(f) x 3/4 npt(m)	1
3a	157785	. UNION, swivel; 3/4-in (19.1 mm)	1	5b	100627	. NIPPLE, short; 3/4 npt	1
3b	241694	. HOSE, fluid, coupled; 4-ft (1.2 m)	1	5c	109077	. VALVE, ball; 3/4 npt	1
3c	100627	. NIPPLE, short; 3/4 npt	2	5d	113902	. COUPLER, camlock, male; 3/4	1
				5e	113907	. COUPLER, camlock, female; 3/4	1

\* Item 4a is only available as part of Kit 224835.

# Parts

## Model 222090, Series A

Wall-mount 1040 diaphragm pump system without used-oil receiver (includes items 1 through 5)

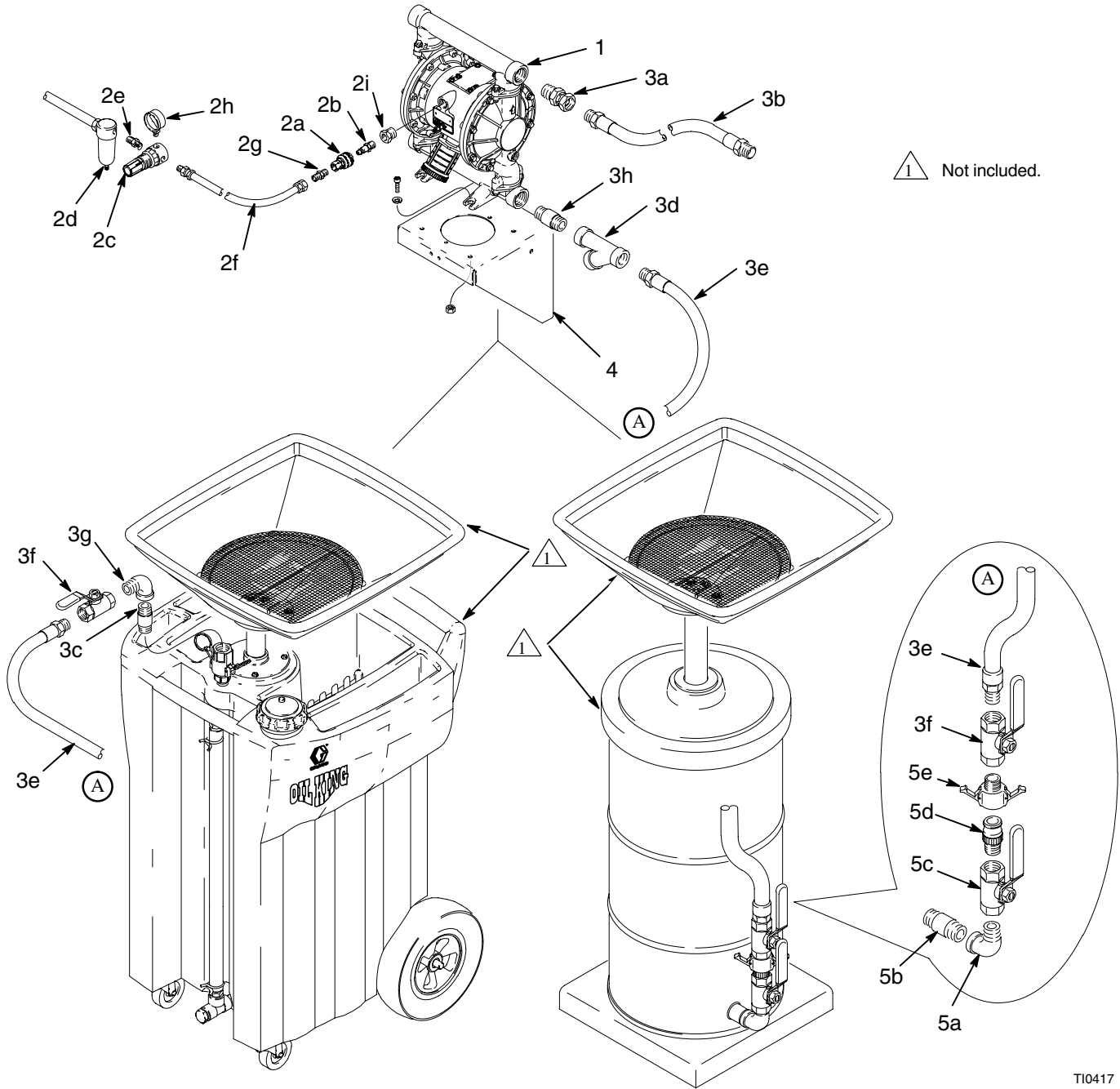

T10417

# Parts

## Model 222090, Series A

Wall-mount 1040 diaphragm pump system without used-oil receiver *(includes items 1 through 5)*

Ref No.	Part No.	Description	Qty.	Ref No.	Part No.	Description	Qty.
1	236265	1040, 1-in (25.4 mm) diaphragm pump <i>(See manual 308326)</i>	1	3b	241694	. HOSE, fluid, coupled; 4-ft (1.2 m)	1
2	240684	KIT, installation, air <i>(includes items 2a through 2j)</i>		3c	100627	. NIPPLE, short; 3/4 npt	1
2a	114558	. COUPLER, female, air line; 1/4-in (6.4 mm)	1	3d	101078	. Y-STRAINER, female; 3/4 npt	1
2b	169970	. FITTING, male, air line; 1/4-in (6.4 mm)	1	3e	111010	. HOSE, fluid, coupled; 10 ft (3.1 m)	1
2c	104815	. REGULATOR, air; 1/8 npt	1	3f	109077	. VALVE, ball; 3/4 npt	1
2d	110146	. FILTER, air; 1/4 npt	1	3g	100549	. ELBOW, street; 3/4 npt(f) x 3/4 npt(m)	1
2e	151519	. NIPPLE; 1/4 npt x 1/8 npt	1	3h	158555	. NIPPLE; 1 npt x 3/4 npt	1
2f	183595	. HOSE, air; 30-in (762 mm)	1	4	189233	KIT, accessory, wall bracket	1
2g	162453	. NIPPLE; 1/4 npt x 1/4 npsm	1	5	240832	KIT, adapter, drum-style; <i>(includes items 5a through 5e)</i>	1
2h	104655	. GAUGE, air pressure; 1/8 npt	1	5a	100549	. ELBOW, street; 3/4 npt(f) x 3/4 npt(m)	1
2j	100206	. BUSHING; 1/2 npt x 1/4 npt	1	5b	100627	. NIPPLE, short; 3/4 npt	1
3	240685	KIT, installation, fluid <i>(includes items 3a through 3h)</i>		5c	109077	. VALVE, ball; 3/4 npt	1
3a	202965	. UNION, swivel; 1 npt(m) x 3/4 npsm(f)	1	5d	113902	. COUPLER, camlock, male; 3/4	1
				5e	113907	. COUPLER, camlock, female; 3/4	1

# Parts

## Model 24E166, Series A

Wall-mount 1050 diaphragm pump system without used-oil receiver (includes items 1 through 5)

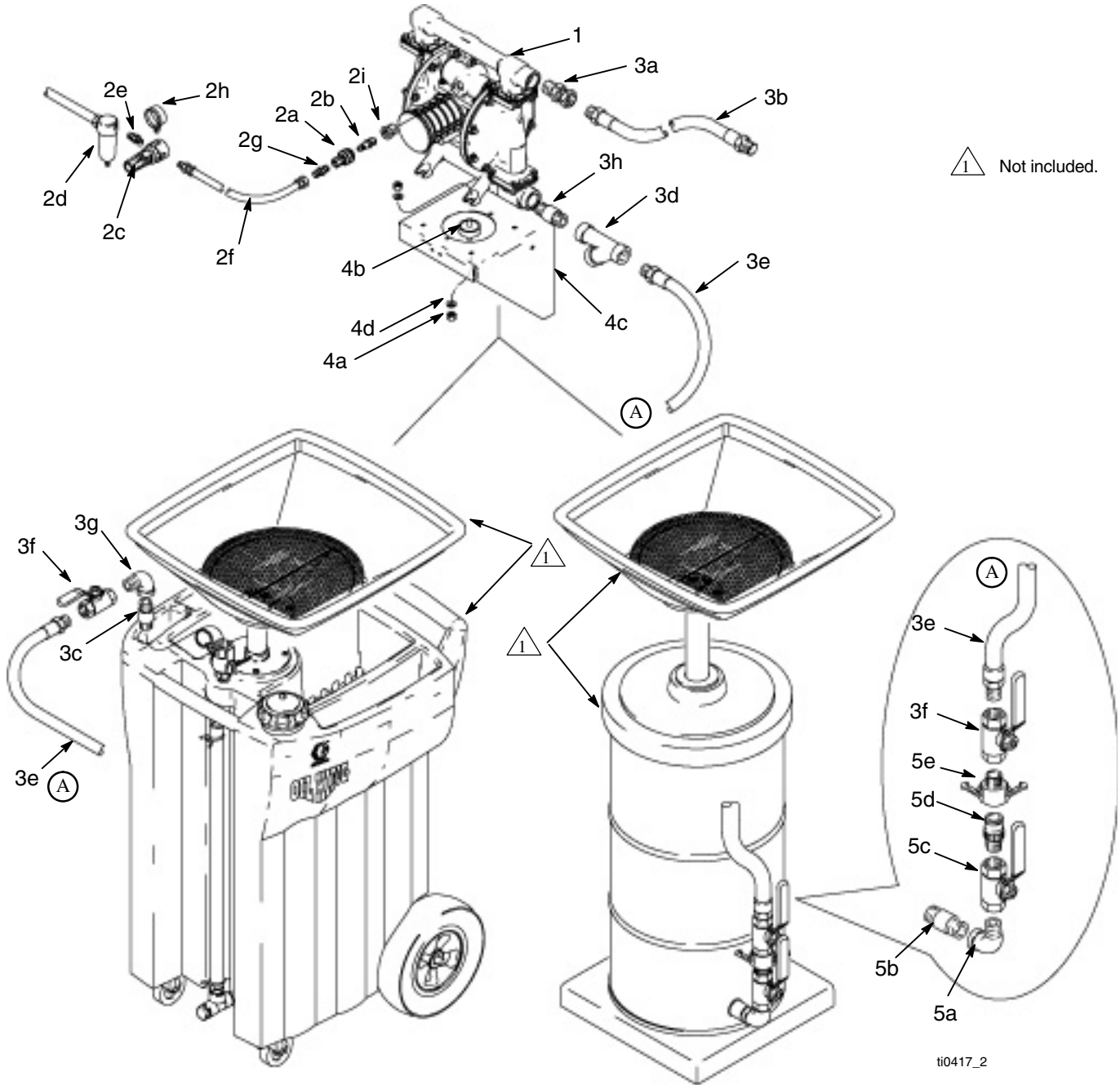

# Parts

## Model 24E166, Series A

Wall-mount 1050 diaphragm pump system without used-oil receiver *(includes items 1 through 5)*

Ref No.	Part No.	Description	Qty.	Ref No.	Part No.	Description	Qty.
1	647016	1050, 1-inch (25.4 mm) diaphragm pump <i>(See manual 313597)</i>	1	3d	101078	. Y-STRAINER, female; 3/4 npt	1
2	240684	KIT, installation, air <i>(includes items 2a through 2j)</i>		3e	111010	. HOSE, fluid, coupled; 10 ft (3.1 m)	1
2a	114558	. COUPLER, female, air line; 1/4-in (6.4 mm)	1	3f	109077	. VALVE, ball; 3/4 npt	1
2b	169970	. FITTING, male, air line; 1/4-in (6.4 mm)	1	3g	100549	. ELBOW, street; 3/4 npt(f) x 3/4 npt(m)	1
2c	104815	. REGULATOR, air; 1/8 npt	1	3h	158555	. NIPPLE; 1 npt x 3/4 npt	1
2d	110146	. FILTER, air; 1/4 npt	1	4	24C637	KIT, accessory, wall bracket <i>(includes 4a through 4d)</i>	1
2e	151519	. NIPPLE; 1/4 npt x 1/8 npt	1	4a	111040	. NUT, lock	8
2f	183595	. HOSE, air; 30-in (762 mm)	1	4b	16D786	. DAMPER, cylindrical	4
2g	162453	. NIPPLE; 1/4 npt x 1/4 npsm	1	4c	16D787	. BRACKET, wall mount	1
2h	104655	. GAUGE, air pressure; 1/8 npt	1	4d	556521	. WASHER	8
2j	100206	. BUSHING; 1/2 npt x 1/4 npt	1	5	240832	KIT, adapter, drum-style; <i>(includes items 5a through 5e)</i>	1
3	240685	KIT, installation, fluid <i>(includes items 3a through 3h)</i>		5a	100549	. ELBOW, street; 3/4 npt(f) x 3/4 npt(m)	1
3a	202965	. UNION, swivel; 1 npt(m) x 3/4 npsm(f)	1	5b	100627	. NIPPLE, short; 3/4 npt	1
3b	241694	. HOSE, fluid, coupled; 4-ft (1.2 m)	1	5c	109077	. VALVE, ball; 3/4 npt	1
3c	100627	. NIPPLE, short; 3/4 npt	1	5d	113902	. COUPLER, camlock, male; 3/4	1
				5e	113907	. COUPLER, camlock, female; 3/4	1

# Graco Standard Warranty

Graco warrants all equipment manufactured by Graco and bearing its name to be free from defects in material and workmanship on the date of sale by an authorized Graco distributor to the original purchaser for use. With the exception of any special, extended, or limited warranty published by Graco, Graco will, for a period of twelve months from the date of sale, repair or replace any part of the equipment determined by Graco to be defective. This warranty applies only when the equipment is installed, operated and maintained in accordance with Graco's written recommendations.

This warranty does not cover, and Graco shall not be liable for general wear and tear, or any malfunction, damage or wear caused by faulty installation, misapplication, abrasion, corrosion, inadequate or improper maintenance, negligence, accident, tampering, or substitution of non-Graco component parts. Nor shall Graco be liable for malfunction, damage or wear caused by the incompatibility of Graco equipment with structures, accessories, equipment or materials not supplied by Graco, or the improper design, manufacture, installation, operation or maintenance of structures, accessories, equipment or materials not supplied by Graco.

This warranty is conditioned upon the prepaid return of the equipment claimed to be defective to an authorized Graco distributor for verification of the claimed defect. If the claimed defect is verified, Graco will repair or replace free of charge any defective parts. The equipment will be returned to the original purchaser transportation prepaid. If inspection of the equipment does not disclose any defect in material or workmanship, repairs will be made at a reasonable charge, which charges may include the costs of parts, labor, and transportation.

**THIS WARRANTY IS EXCLUSIVE, AND IS IN LIEU OF ANY OTHER WARRANTIES, EXPRESS OR IMPLIED, INCLUDING BUT NOT LIMITED TO WARRANTY OF MERCHANTABILITY OR WARRANTY OF FITNESS FOR A PARTICULAR PURPOSE.**

Graco's sole obligation and buyer's sole remedy for any breach of warranty shall be as set forth above. The buyer agrees that no other remedy (including, but not limited to, incidental or consequential damages for lost profits, lost sales, injury to person or property, or any other incidental or consequential loss) shall be available. Any action for breach of warranty must be brought within two (2) years of the date of sale.

Graco makes no warranty, and disclaims all implied warranties of merchantability and fitness for a particular purpose in connection with accessories, equipment, materials or components sold but not manufactured by Graco. These items sold, but not manufactured by Graco (such as electric motors, switches, hose, etc.), are subject to the warranty, if any, of their manufacturer. Graco will provide purchaser with reasonable assistance in making any claim for breach of these warranties.

In no event will Graco be liable for indirect, incidental, special or consequential damages resulting from Graco supplying equipment hereunder, or the furnishing, performance, or use of any products or other goods sold hereto, whether due to a breach of contract, breach of warranty, the negligence of Graco, or otherwise.

## **FOR GRACO CANADA CUSTOMERS**

The parties acknowledge that they have required that the present document, as well as all documents, notices and legal proceedings entered into, given or instituted pursuant hereto or relating directly or indirectly hereto, be drawn up in English. Les parties reconnaissent avoir convenu que la rédaction du présente document sera en Anglais, ainsi que tous documents, avis et procédures judiciaires exécutés, donnés ou intentés à la suite de ou en rapport, directement ou indirectement, avec les procédures concernées.

# Graco Phone Numbers

**TO PLACE AN ORDER**, contact your Graco distributor, or call one of the following numbers to identify the distributor closest to you:

**1-800-533-9655 Toll Free**

**612-623-6928**

**612-378-3590 Fax**

*All written and visual data contained in this document reflects the latest product information available at the time of publication.  
Graco reserves the right to make changes at any time without notice.*

*Original instructions. This manual contains English. MM 308719*

**Graco Headquarters:** Minneapolis

**International Offices:** Belgium, China, Japan Korea

**GRACO INC. P.O. BOX 1441 MINNEAPOLIS, MN 55440-1441**

Copyright 1998, Graco Inc. is registered to I.S. EN ISO 9001

[www.graco.com](http://www.graco.com)

PRINTED IN USA 308719 06/1998 Revised 11/2010